

SUNRISE

Punching Machine with NC feeder
For angles, channels and flat plates

PM-80T-ANC1 Specifications

Punching Machine

Punching pressure	80 Tons
Max. capacity on flat bar	Ø30x18mm
Max. capacity on angle/channel	Ø30x10mm
Throat depth	310mm
Max. stroke length	100mm
Cycles / Min. (15mm stroke)	28
Motor	7.5 HP

Feeder Spec.

Feeder length (X-axis)	3000mm
Feeder Y-axis range	310mm
Servo motor	500W
Gear speed reduction	1:10 ratio
Feeder speed	10m/min.
Accuracy	±0.3mm per meter

Features

NC control	1 axis
Program storage	100 programs
Pattern holes	999 holes/program
Custom holes	24 holes/program
Angle size range	3"~ 8"
Channel size range (flange)	3"~ 7"
Channel size range (web)	3"~ 12"
Clamp type	Pneumatic
Clamping force	340 kgs
Standard stripper	Hydraulic type
Standard die holder	O.D. Ø45mm gooseneck
Die holder height	177mm
Working height up to die	1050mm

Based on material strength of 45 kg/mm² tensile.
Design subject to change without notice.

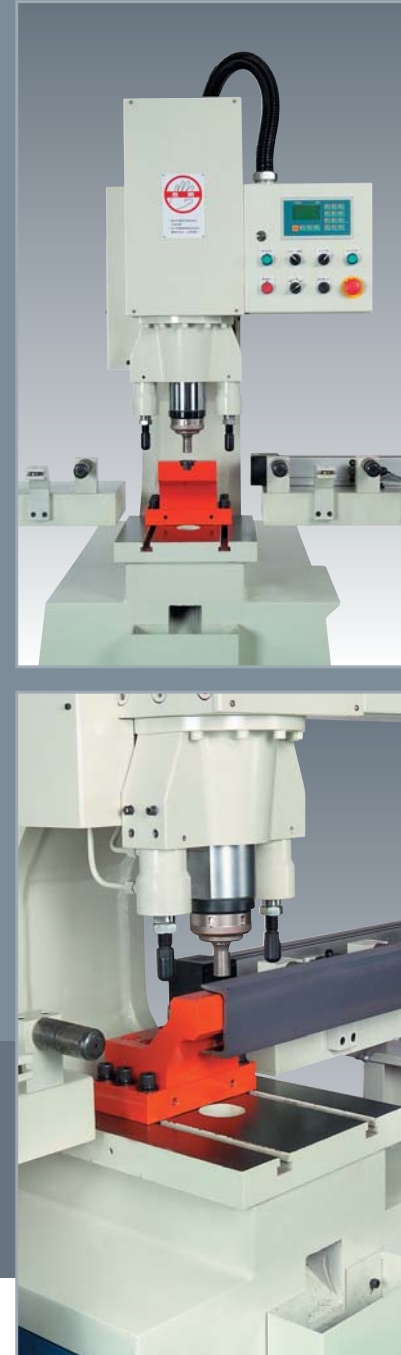



PM-80T-ANC1

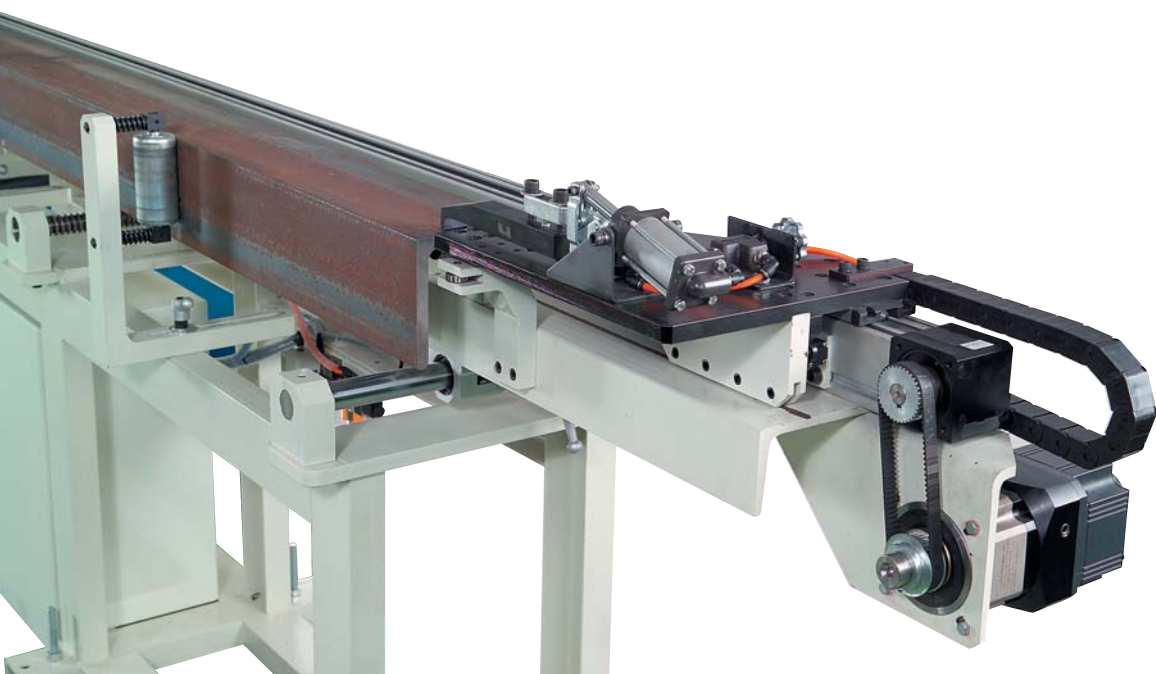

- 3 Meter length auto feeder.
- Servo motor driven with geared speed reduction to increase torque and improves accuracy.
- Simple to use controller interface.
- Movement in Y-axis by handwheel and ball screws for fine adjustment.
- Air cylinder clamps.
- Wide range of material can be punched: Angles, channels, and flat plates.

